

# BAXI



## Eco5 Compact

SPARE PARTS CATALOGUE

- September 2019 -



## HOW TO READ THE SPARE PARTS CATALOGUE

In the spare part catalogue, after the exploded diagrams, there are the components lists of the boilers; this is the meaning of the different columns:

Pos. Identification number of the component in the exploded diagram of the boiler.

Description Short description of the component.

Code BAXI S.p.A. code of the component.

Tab. XX XX is the exploded diagram number of the boiler taken into consideration.

### Until 31th december 2011

From serial number Date (year and week) identifying the beginning of production of a component (taken from the serial number of the boiler).  
e.g. B005: year 2000 (B identifies the decade 2000-2009; 0 identifies the year) – 5th week.  
If the box is empty, the component is in use from the beginning of production of the boiler.

To serial number Date (year and week) identifying the end of production of a component (taken from the serial number of the boiler).  
e.g. B012: year 2000 (B identifies the decade 2000-2009; 0 identifies the year) – 12th week.  
If the box is empty, the component is still in use.

Interchangeable It identifies the interchangeability between the new component and the old one.  
YES: components are interchangeable.  
NO: components are not interchangeable.

### Form 1st January 2012

From serial number Date (year and week) identifying the beginning of production of a component (taken from the serial number of the boiler).  
e.g. 1201: year 2012 (1 identifies the decade 2010-2019; 2 identifies the year) – 01th week.  
If the box is empty, the component is in use from the beginning of production of the boiler.

To serial number Date (year and week) identifying the end of production of a component (taken from the serial number of the boiler).  
e.g. 1225: year 2012 (1 identifies the decade 2010-2019; 2 identifies the year) – 25th week.  
If the box is empty, the component is still in use.

Interchangeable It identifies the interchangeability between the new component and the old one.  
YES: components are interchangeable.  
NO: components are not interchangeable.

**TABELLA COLLEGAMENTO CODICE CALDAIA - ESPLOSO**  
**TABLEAU CONNECTION CODEX CHAUDIERE - VUE ECLATEE**  
**BOILERS CONNECTION BOARD - EXPLODED VIEW**

<b>BOILER CODE</b>	<b>BOILER DESCRIPTION</b>	<b>EXPLODED REF.</b>
<b>CODICE CALDAIA</b>	<b>DESCRIZIONE CALDAIA</b>	<b>RIF. ESPLOSO</b>
<b>CODIGO CALDERA</b>	<b>DESCRIPCION CALDERA</b>	<b>REF. EXPLOSIONADO</b>
<b>CODE CHAUDIÈRE</b>	<b>DESCRIPTION CHAUDIÈRE</b>	<b>RÉF. EXPLOSÉE</b>
711573702/3	ECO5 COMPACT 1.14 F	Tab 500
721425402/3	ECO5 COMPACT 1.24	Tab 532
711287002/3	ECO5 COMPACT 1.24 F	Tab 500
7729433	ECO5 COMPACT 14 F	Tab 716
711571903/4	ECO5 COMPACT 14 F	Tab 488
7729434	ECO5 COMPACT 18 F	Tab 716
711572003/4	ECO5 COMPACT 18 F	Tab 488
7729432	ECO5 COMPACT 24	Tab 726
721425503/4	ECO5 COMPACT 24	Tab 531
7729435	ECO5 COMPACT 24 F	Tab 716
710506504/5	ECO5 COMPACT 24 F	Tab 488
7729436	ECO5 COMPACT 24 F GPL	Tab 716
711314002/3	ECO5 COMPACT 24 F GPL	Tab 488

# Eco5 compact

Pos	Code	Description code	711573702/3 1,14F	711287002/3 1,24F	721425402/3 1,24	711571902/3 14F	7729433 14F	711572002/3 18F	7729434 18F	721425503/4 24	7729432 24	710506504/5 24F	7729435 24F	711314002/3 24F GPL	7729436 24F GPL	To serial number	From serial number	Interchan geable:
2	5698660	LEFT PANEL ASSEMBLY ECO4 ATM.			•					•	•							
2	710556300	LEFT PANEL ASSEMBLY	•	•		•		•				•		•		1707		
2	767299100	LEFT PANEL ASSEMBLY					•		•				•		•			
2	767299100	LEFT PANEL ASSEMBLY	•	•		•		•				•		•			1708	YES
3	5698650	RIGHT PANEL ASSEMBLY ECO4 ATM.			•					•	•							
3	710556400	RIGHT PANEL ASSEMBLY	•	•		•		•				•		•		1707		
3	767299000	RIGHT PANEL ASSEMBLY					•		•				•		•			
3	767299000	RIGHT PANEL ASSEMBLY	•	•		•		•				•		•			1708	YES
4	722393700	FRONTAL PANEL ECO5 COMPACT FF	•	•		•		•				•		•		1707		
4	722393800	FRONTAL PANEL ECO5 COMPACT ATM			•					•	•							
4	767299400	FRONTAL PANEL ECO5 COMPACT FF	•	•		•		•				•		•			1708	YES
4	767299400	FRONTAL PANEL ECO5 COMPACT FF					•		•				•		•			
5	5117460	TRAVERSE SIDES CONNECTION-ATM-			•					•	•							
9	631760	FLUE RESTRICTOR MAIN5		•		•		•				•	•	•	•			
9	631950	FLUE RESTRICTOR MAIN5	•			•		•										
21	5402050	WASHER-SEALING			•					•	•							
22	710365100	FAN 30W	•	•		•	•	•	•			•	•	•	•			
25	710808100	COMBUSTION CHAMBER ASSEMBLY	•	•		•	•	•	•			•	•	•	•			
27	5698630	COMBUST. CHAMBER ASS. ECO4 ATM			•					•	•							
27	710507500	C FRAME ECO5	•	•		•	•	•	•			•	•	•	•			
28	5213220	INSULATING PANEL			•					•	•							
28	710495700	LATERAL INSULATING PANEL	•	•		•	•	•	•			•	•	•	•			
29	5213280	INSULATING PANEL			•					•	•							
29	710495600	REAR INSULATING PANEL	•	•		•	•	•	•			•	•	•	•			
30	5213380	FRONTAL INSULATING PANEL			•					•	•							
30	710391300	FRONTAL INSULATING PANEL	•	•		•	•	•	•			•	•	•	•			
31	615370	COMBUST.CHAMBER FRONTAL PANEL			•					•	•							
32	5677660	PRIMARY EXCHANGER WITH CLIPS			•					•	•							
32	710592300	H2O/EXCHANGER ECO5	•	•		•	•	•	•			•	•	•	•			
33	710963000	OR 21,5X3 EP70 TFL	•	•	•	•	•	•	•	•	•	•	•	•	•			

# Eco5 compact

Pos	Code	Description code	7115737023 1.14F	7112870023 1.24F	7214254023 1.24	7115719023 14F	7115719023 14F	7729433 18F	7115720023 18F	7729434 18F	24	7214255034 24	7729432 24	7105065045 24F	7729435 24F	7113140023 24F GPL	7729436 24F GPL	To serial number	From serial number	Interchan geable:
34	5113650	PRIMARY EXCHANGER FIXING CLIP	•	•	•	•	•	•	•	•	•	•	•	•	•	•	•			
34	8380860	FIXING CLIP					•			•			•		•		•			
35	5693900	RECT.EXPANSION VESSEL 6I-CIMM-			•							•	•							
35	710418200	EXPANSION VESSEL 8L CIMM	•	•		•	•	•	•					•	•	•	•			
36	5698830	PIPE EXPANSION VESSEL			•							•								
36	7740989	EXPANSION VESSEL PIPE					•			•					•		•			
36	711412700	EXPANSION VESSEL PIPE ECO5	•	•		•		•						•		•				
37	710795800	SEALED CHAMBER FRONT PANEL	•	•		•	•	•	•					•	•	•	•			
41	5663710	BURNER ASSEMBLY (13 ELEM.)			•						•	•								
41	710516000	BURNER 11 ELEMENTS	•	•		•	•	•	•					•	•	•	•			
43	5698690	GAS RAMP 13HOLES/INJECT. d1,18			•							•	•							
43	710807300	GAS RAMP 11 INJECTORS	•	•		•		•						•	•					
43	711176900	GAS RAMP 11 INJECTORS d 1,18					•			•										
44	5209150	INJECTOR D. 1,18 MM	•			•	•	•	•											
44	5210790	INJECTOR (1x0,85) LPG															•			
44	5214470	INJECTOR diameter 1,35 mm		•										•	•					
44	5680020	TRANSFORMATION KIT G31			•							•	•							
44	5704730	KIT TRANSF.GAS G31 11x0,85		•										•	•					
44	711368500	KIT TRANSF. G31 11X0,77	•			•		•												
45	5407940	GASKET-BURNER MANIFOLD			•						•	•								
46	5657180	ADAPTOR-MANIFOLD			•						•	•								
48	710733000	BURNER TRAY	•	•		•	•	•	•					•	•	•	•			
49	5409520	HOSE ADAPTER CAP	•	•		•	•	•	•					•	•	•	•			
59	721426600	IGNITION CABLE			•						•	•								
61	5407830	INSULATION BOOT - ELECTRODE			•						•	•								
63	8422570	ELECTRODE - IGNITION			•						•	•								
63	711404900	ELECTRODE	•	•		•	•	•	•					•	•	•	•			
70	5698720	PIPE PUMP/EXCHANGER ATM BITRON			•						•	•								
70	710593900	PIPE PUMP/EXCHANGER	•	•		•	•	•	•					•	•	•	•			

# Eco5 compact

Pos	Code	Description code	711573702/3 1.14F	711287002/3 1.24F	721425402/3 1.24	711571902/3 14F	7729433 14F	711572002/3 18F	7729434 18F	721425503/4 24	7729432 24	710506504/5 24F	7729435 24F	711314002/3 24F GPL	7729436 24F GPL	To serial number	From serial number	Interchan geable:
72	721957600	PUMP 5M NO CE	•	•	•	•	•	•	•	•	•	•	•	•	•			
73	7219215	AIR VENT PUMP WL.	•	•	•	•	•	•	•	•	•	•	•	•	•			
76	5686660	DHW PLATE EXCHANGER 10 PLATES				•	•	•	•	•	•	•	•	•	•			
77	5404520	DHW PLATE EXCHANGER GASKET				•	•	•	•	•	•	•	•	•	•			
80	711033700	COMBI HYDROBLOCK RETURN BIT. ECO4								•								
81	710048100	DHW CARTRIDGE				•	•	•	•	•	•	•	•	•	•			
90	710046600	FILLING TAP ASSY	•	•	•	•		•		•		•		•		1639		
90	766947000	FILLING TAP ASSY	•	•	•	•		•		•		•		•		1824	1640	YES
90	768777500	FILLING TAP ASSY	•	•	•	•		•		•		•		•			1825	YES
90	768777500	FILLING TAP ASSY					•		•		•		•					
91	710045500	DISCHARGE TAP CONNECTION	•	•	•	•		•		•		•		•				
92	7728736	SAFETY VALVE					•		•		•		•		•			
92	710071200	SAFETY VALVE 3 bar NOVASFER			•					•								
92	710109400	HYDRAULIC SAFETY VALVE 3 BAR	•	•		•		•				•		•				
98	710046300	BY-PASS CONNECTION ASSY	•	•	•	•		•		•		•		•				
102	711033600	COMBI HYDROBLOCK DELIVERY BIT. EC								•								
113	710048300	BY-PASS CARTRIDGE	•	•	•	•		•		•		•		•				
114	710046400	O-RING d.15,54X2,62	•	•	•	•		•		•		•		•				
120	7728745	3 WAY VALVE CARTRIDGE					•		•		•		•		•			
120	721403800	3WV CARTRIDGE				•		•		•		•		•				
122	710047800	O-RING d.23,47X2,62				•	•	•	•	•	•	•	•	•	•			
128	710048800	O-RING d.8,9X1,9	•	•	•	•	•	•	•	•	•	•	•	•	•			
131	721309400	NTC SENSOR NICKEL				•	•	•	•	•	•	•	•	•	•			
132	710049100	O-RING d.11,91X2,62 OR115				•	•	•	•	•	•	•	•	•	•			
135	9951610	LIMIT THERMOSTAT 105°C	•	•	•	•	•	•	•	•	•	•	•	•	•			
136	5698740	PIPE EXCH./H.INLET ECO4 ATM			•					•								
136	7730225	FLOW PIPE					•		•				•		•			
136	7730232	FLOW PIPE									•							
136	711159000	PIPE EXCHANG./INLET ECO5	•	•		•		•				•		•				

# Eco5 compact

Pos	Code	Description code	711573702/3 1.14F	711287002/3 1.24F	721425402/3 1.24	711571902/3 14F	7729433 14F	711572002/3 18F	7729434 18F	721425503/4 24	7729432 24	710506504/5 24F	7729435 24F	711314002/3 24F GPL	7729436 24F GPL	To serial number	From serial number	Interchan geable:
137	710585800	CONNECTION GAS VALVE/OR	•	•		•	•	•	•			•	•	•	•			
137	721345600	GAS VALVE CONNECTING ELEMENT			•					•	•							
138	5402010	O RING 22.22x2.62	•	•	•	•	•	•	•	•	•	•	•	•	•			
140	710660400	GAS VALVE VK4105M	•	•	•	•	•	•	•	•	•	•	•	•	•			
147	711457300	CONNECTION TRAVERSE			•					•	•							
151	710654600	BOX COVER	•	•	•	•	•	•	•	•	•	•	•	•	•			
152	710626400	CONTROL PANEL MAIN5	•	•		•	•	•	•			•	•	•	•			
152	711454800	CONTROL PANEL			•					•	•							
154	721824700	PCB HON. ECO5/MAIN5	•	•	•	•		•		•		•		•		1620		
154	766077600	PCB HON. ECO5/MAIN5	•	•	•	•		•		•		•		•		1638	1621	YES
154	766487600	PCB ECO5/MAIN5					•		•		•		•	•				
154	766487600	PCB ECO5/MAIN5	•	•	•	•		•		•		•		•			1639	YES
166	5688430	TERM.BOARD/DOUBLE FUSE HOLDER	•	•	•	•	•	•	•	•	•	•	•	•	•			
168	9950580	FUSE	•	•	•	•	•	•	•	•	•	•	•	•	•			
169	7723441	MANOMETER D.28					•		•				•	•				
169	710673600	MANOMETER D.28	•	•	•	•		•		•		•		•				
170	711457500	CONTROL PANEL SUPPORT			•					•	•							
174	710830500	KEYBOARD MAIN5/ECO5	•	•	•	•	•	•	•	•	•	•	•	•	•			
192	5404650	SEALING WASHER G 3/4	•	•	•	•	•	•	•	•	•	•	•	•	•			
208	710635700	CONNECTING ELEMENT M/F G3/4	•	•	•	•	•	•	•	•	•	•	•	•	•			
231	710452800	FLUE INTAKE	•	•		•	•	•	•			•	•	•	•			
241	5668420	CONVEYOR ASSEMBLY			•					•	•							
242	616160	FLUE SAFETY THERMOSTAT 70ø			•					•	•							
242	710743700	FLUE SENSOR/CABLE	•	•		•	•	•	•			•	•	•	•			
259	710419300	BRAND BAXI	•	•	•	•	•	•	•	•	•	•	•	•	•			
305	710495200	FAN BRACKET	•	•		•	•	•	•			•	•	•	•			
322	710538300	CLIP TH	•	•		•	•	•	•			•	•	•	•			
336	710047400	CLIP - 3WV MOTOR HEAD				•	•	•	•	•	•	•	•	•	•			
337	710047300	3WV MOTOR HEAD				•	•	•	•	•	•	•	•	•	•			

# Eco5 compact

Pos	Code	Description code	711573702/3 1.14F	711287002/3 1.24F	721425402/3 1.24	711571902/3 14F	711572002/3 18F	7729433 14F	7729434 18F	721425503/4 24	7729432 24	710506504/5 24F	7729435 24F	711314002/3 24F GPL	7729436 24F GPL	To serial number	From serial number	Interchan geable:
340	721384000	ON/OFF CH PRESSURE SWITCH	•	•	•	•	•	•	•	•	•	•	•	•	•			
363	710045300	O-RING d.17,96X2,62	•	•	•	•	•	•	•	•	•	•	•	•	•			
373	710047100	CH FILTER	•	•	•	•	•	•	•	•	•	•	•	•	•			
511	711230600	OR 17,13X2,62 EP70 TFL	•	•	•	•	•	•	•	•	•	•	•	•	•			
528	710666500	NTC SENSOR D14	•	•		•	•	•	•			•	•	•	•			
528	710702400	NTC SENSOR D18			•					•	•							
600	710045400	CLIP FLAT d.18	•	•	•	•	•	•	•	•	•	•	•	•	•			
624	710976600	HALL SENSOR ASSY				•	•	•	•	•	•	•	•	•	•			
675	710046100	CLIP BRASS ADAPTOR	•	•	•	•	•	•	•	•	•	•	•	•	•			
692	5114360	PRIMARY EXCHANGER CLIPS			•					•	•							
693	710783700	PRINTED CNTR. PANEL PROTECTION	•	•	•	•	•	•	•	•	•	•	•	•	•			
721	710660300	OR d.19,3X3,6 HNBR	•	•	•	•	•	•	•	•	•	•	•	•	•			
763	710046700	CLIP FLAT d.12	•	•	•	•	•	•	•	•	•	•	•	•	•			
764	710047500	CLIP U d.3				•	•	•	•	•	•	•	•	•	•			
765	710045700	O-RING d.9,19 X 2,62	•	•	•	•	•	•	•	•	•	•	•	•	•			
767	710046900	PTP EXCH FIXING SCREW				•	•	•	•	•	•	•	•	•	•			
780	710633100	UPPER SUPPORT	•	•		•	•	•	•			•	•	•	•			
781	710539600	CLIP GAS PIPE	•	•	•	•	•	•	•	•	•	•	•	•	•			
783	710039500	HYDRAULIC GROUP GASKET	•	•		•	•	•	•			•	•	•	•			
788	710176000	COMBUSTION CHAMBER GASKET C	•	•		•	•	•	•			•	•	•	•			
799	710654100	SPRING FIXING D.9	•	•	•	•	•	•	•	•	•	•	•	•	•			
801	710048700	CLIP CH PRESSURE SWITCH	•	•	•	•	•	•	•	•	•	•	•	•	•			
804	5698760	HYDRAULIC GROUP COMBI BITRON								•								
804	5699200	HYDRAULIC GROUP ONLY HEATING			•													
804	7730231	HYDRAULIC GROUP 10P				•		•		•		•		•				
804	711231000	HYDRAULIC GROUP BITRON ECO5				•	•					•		•				
804	711286700	HYDR. GROUP. BITRON ECO5 MONO.	•	•														
806	5117880	CLIP d.10 BITRON	•	•	•	•	•	•	•	•	•	•	•	•	•			
999	8414540	CABLE ROOM TH	•	•		•	•	•	•			•	•	•	•			



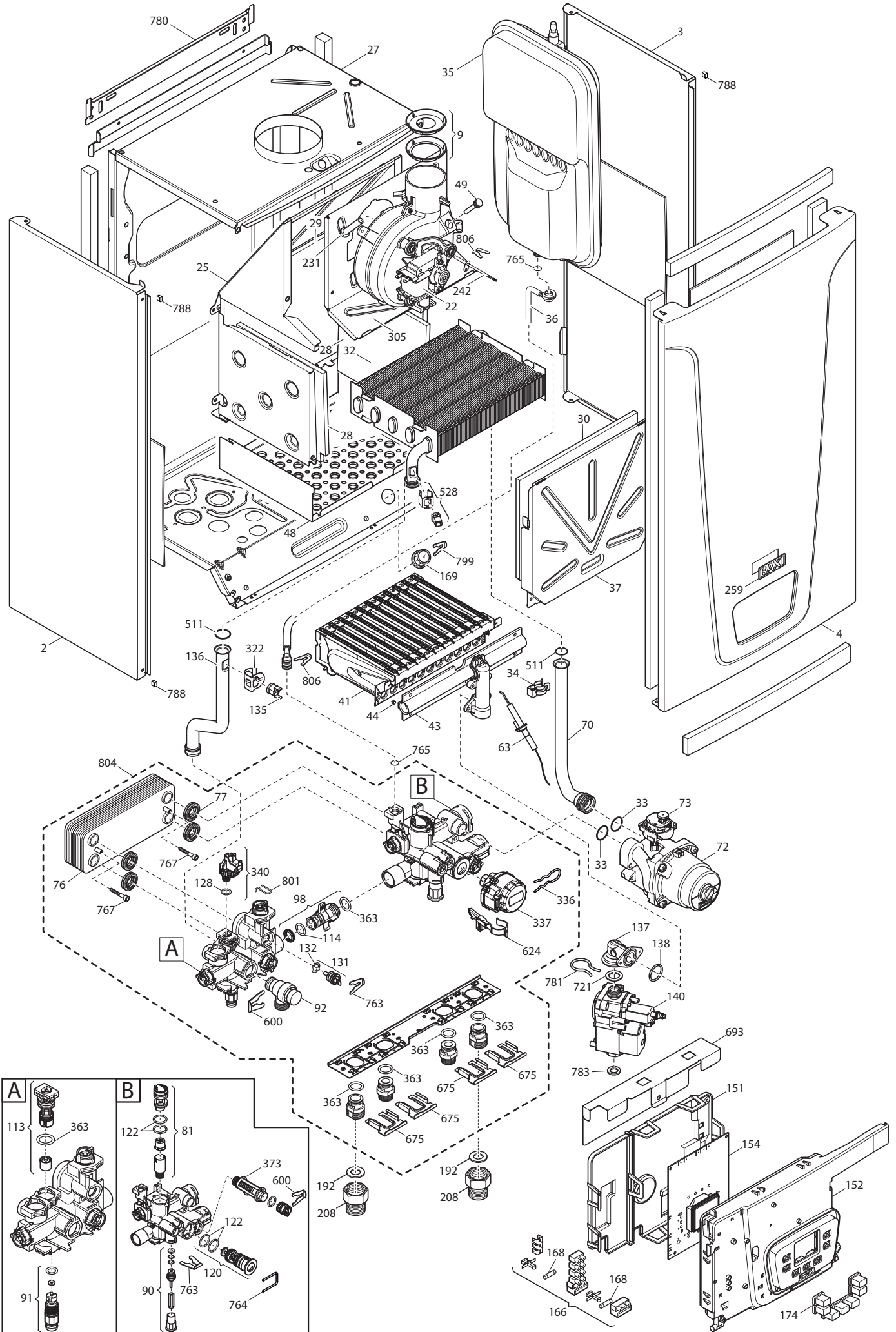

Tab 500

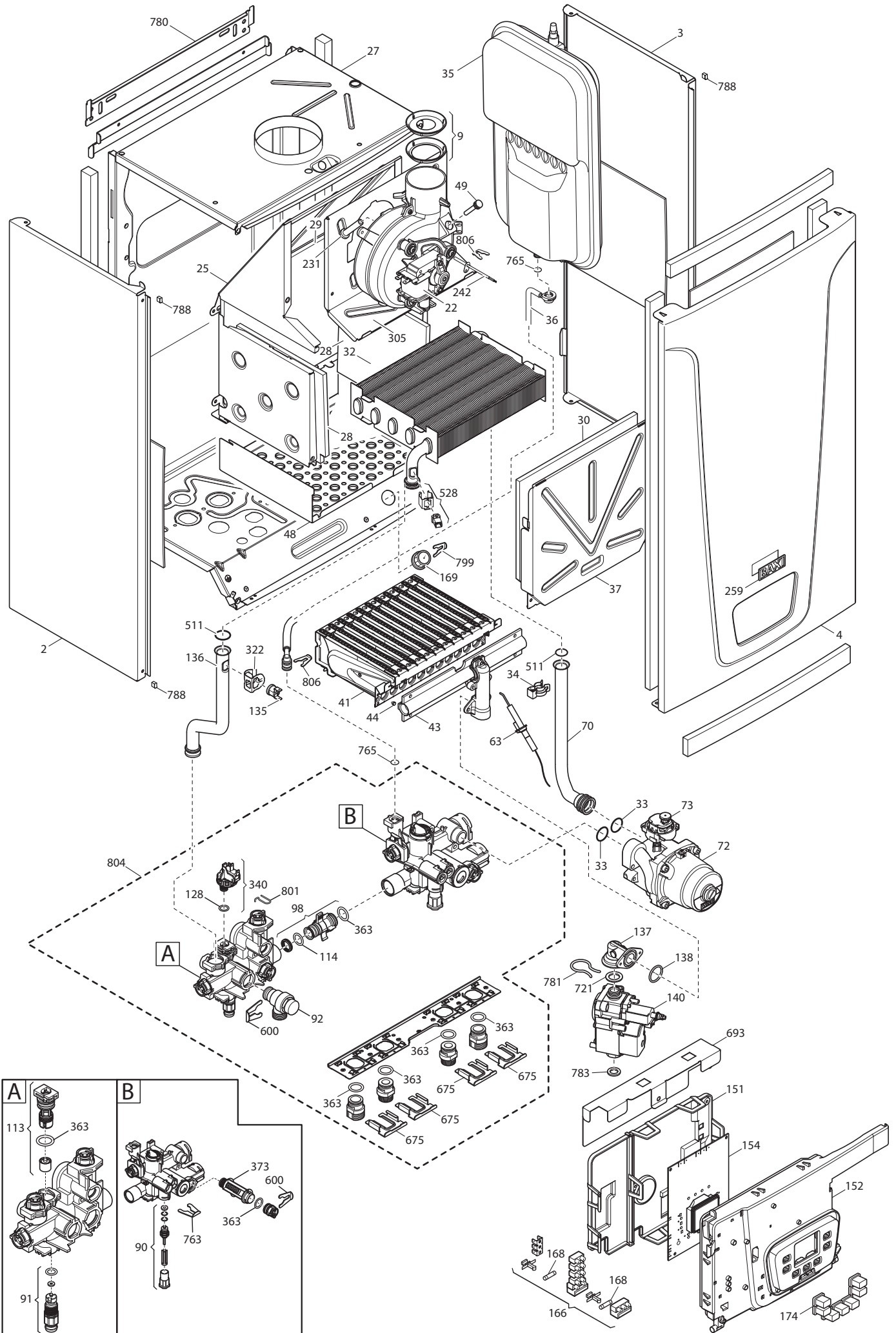

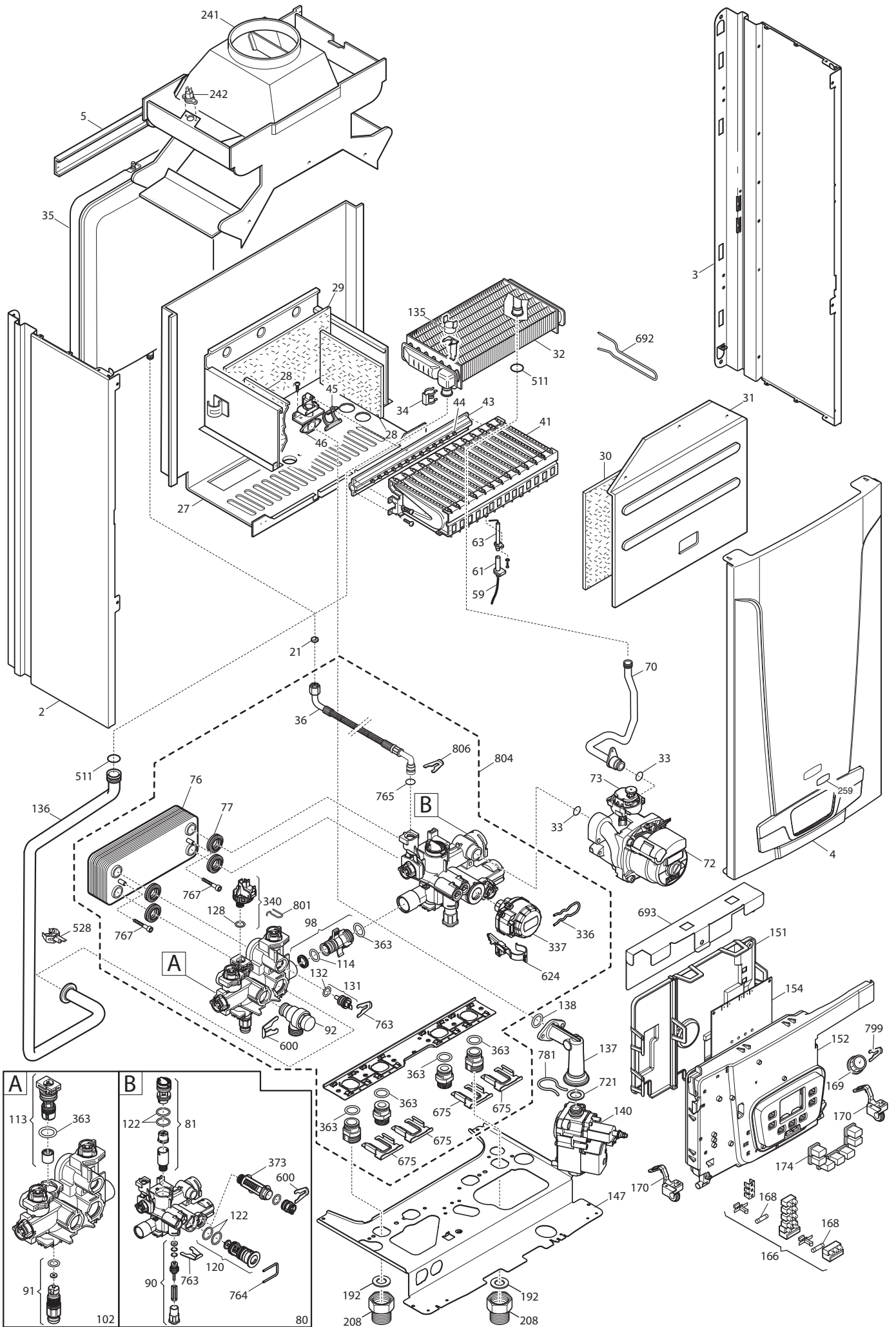

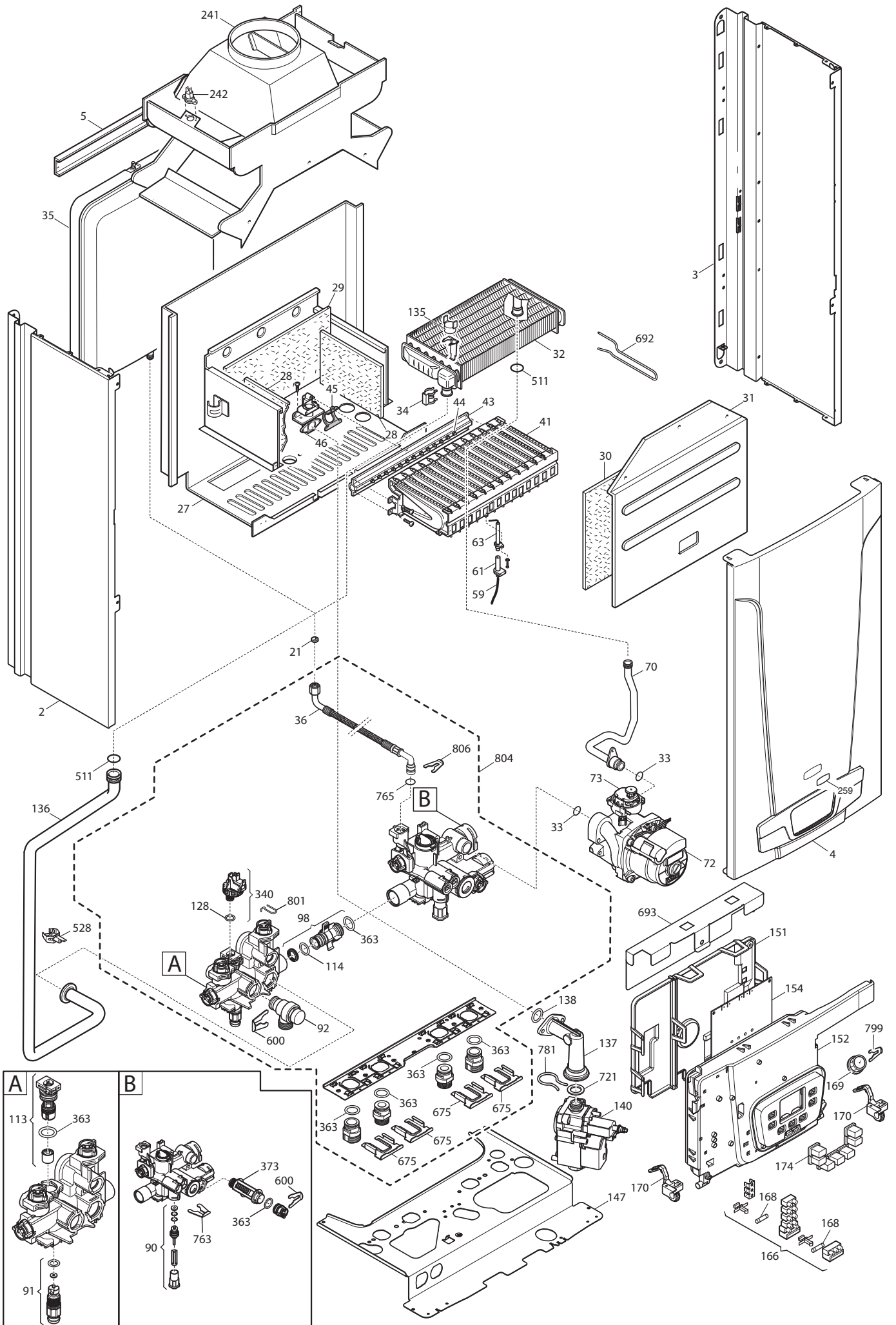

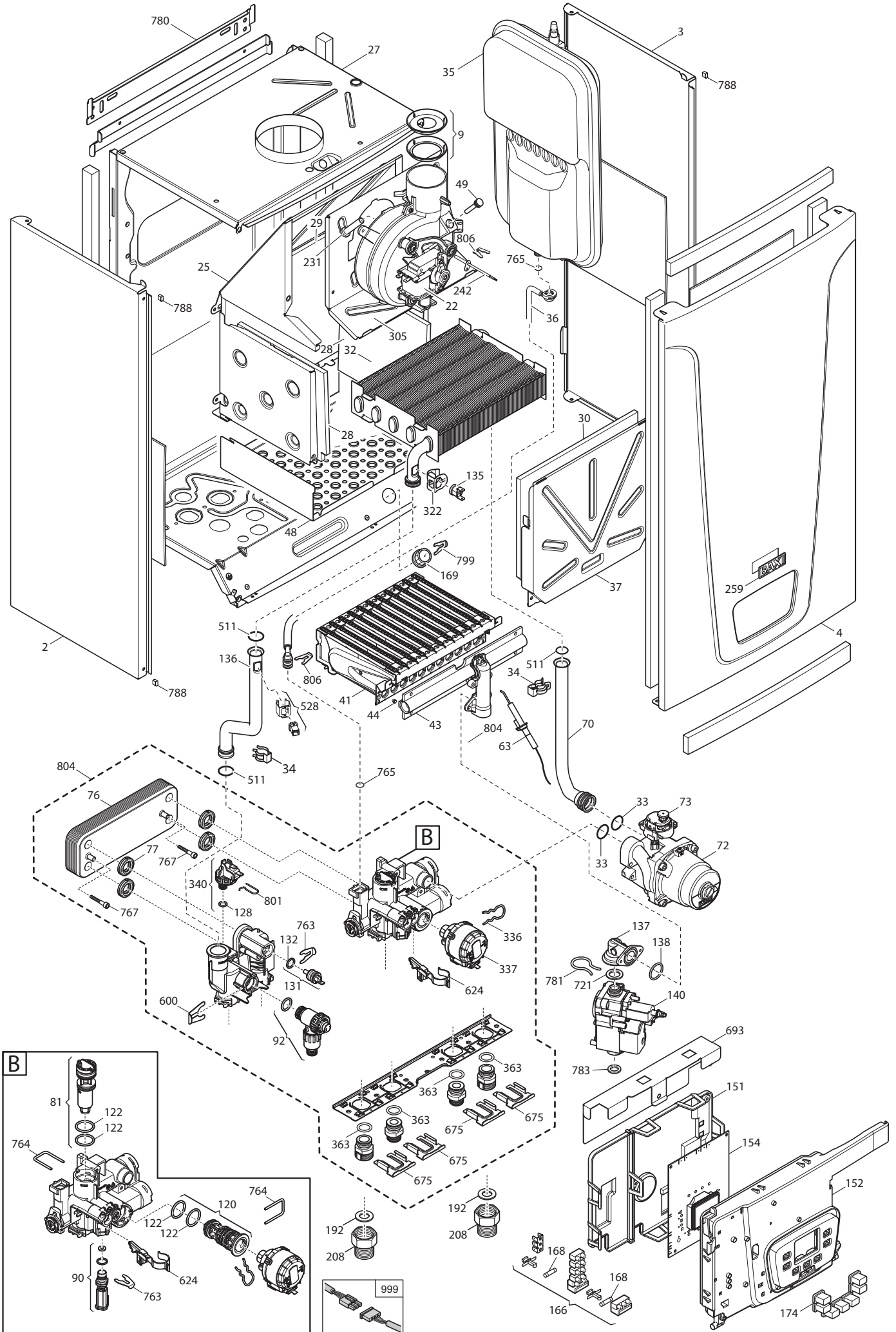

**BAXI**

**BAXI S.p.A.**  
**Via Trozzetti, 20**  
**36061 BASSANO DEL GRAPPA (VI)**  
**ITALY**  
**Tel. +390424517111**  
**Telefax +390424517379**  
**E-mail. [service@baxi.it](mailto:service@baxi.it)**